

 **CPI Daylighting**
Building Envelope Solutions
Imagination Meets Innovation

Quality Comes to Light®

CPI Daylighting is an award-winning innovator of translucent daylighting technology for high-performance building envelopes – walls, skylights and canopies.

Since the 1980s, CPI Daylighting has been a pioneer and leader of the daylighting industry. From our beginnings as a translucent skylight manufacturer to our evolution into the premier innovator of daylighting technology, we have remained committed to raising the standards for daylighting design and inspiring architects to push the envelope.

Our team of highly-skilled & experienced professionals includes designers, architects, engineers and installers. Together, we leverage our knowledge and expertise to serve as the leading daylighting consultants for the architectural community and building industry.



▲ **Project:** AVCRAD Facility id 29452
Location: Springfield, MO
Architect: Jacobs



▲ **Project:** Hologic, Inc. id 34563
Location: San Diego, CA
Architect: Smith Group Consulting



▲ **Project:** UNF Student Center id 24863
Location: Jacksonville, FL
Architect: Rink Design Partnership



The CPI Difference

We believe that good design can have a profoundly positive effect on the built environment, and improve the way that we work, learn, play and live.

Our mission is to set new, higher standards for the quality and versatility of daylighting technology, as we strive to advance daylighting design.

▲ **Project:** Element LA id 39691
Location: Los Angeles, CA
Architect: Gensler

Collaboration is Key

As expert problem-solvers, we team up with architects and designers to develop solutions that will enhance and optimize the role that natural light plays in the design of buildings. We are here to assist you through each step of the process – from preliminary design to the final installation of the system.

Don't Compromise

As a designer, you shouldn't have to compromise your design due to product limitations or the rigidity of some manufacturers. Our goal is to enable architects to achieve the highest levels of building performance without sacrificing the aesthetic quality of their design. This is why we have worked tirelessly to develop the most versatile daylighting system on the market.

Challenge Us

We offer architects the unique opportunity to redefine daylighting. Be creative, and explore new ways to utilize our technology. Push the envelope with your designs, and inspire others to do the same.

We were founded on innovation, but it is your imagination that continues to drive our evolution. So, what's your next bright idea?



Our Innovative Technology

▲ **Project:** Grandview Heights Aquatic Centre id 36690
Location: Surrey, B.C.
Architect: HCMA Architecture + Design

Two-Panel System

Our system is designed with two independent glazing panels that are mechanically connected to an internal support structure. A key feature of this design is the internal cavity between the two glazing panels. The cavity can be filled with various inserts to customize the performance of the system based on the building's requirements. Rather than sourcing a different system for each type of daylighting application, utilize a single, trusted system that is designed to adapt to meet your building performance needs.

Our translucent daylighting system delivers outstanding performance, offering the best ratio of light transmission to insulation value in the industry, and is the ultimate in design freedom and flexibility.



Removable Skin Technology (RST)

The system is designed so that the interior and exterior glazing panels are independent of one another. Once installed, the interior panels remain intact, and each of the exterior panels can be disengaged and removed without compromising the integrity of the building envelope.

Removable skin technology ensures that if there is a future need for updating the exterior, those panels can be changed without interrupting ongoing building operations. The flexibility to replace individual panels, rather than the entire system, adds another level of dimensionality to a system that is already extremely versatile.



Bi-Color Panel Option

A different color can be selected for each of the two independent glazing panels that make up the system. As a designer, you may want to make a bold statement by using colorful panels on the exterior and utilize a neutral panel color on the interior for a clean, finished look.

While glazing color combinations offer an opportunity for creativity, they also serve a practical purpose when tailoring the performance of the system. Each glazing color has an inherent solar performance. By varying the combination of the glazing colors, not only can you create unique visual elements, but you can also customize the solar performance of the system. The optional matte finish on the panels will increase their ability to diffuse light and eliminate glare.



Longer Clear Spans

Due to the design of the internal support structure, the panel system can achieve longer spans and still comply with deflection and code requirements. The ability to span floor-to-slab minimizes the necessary support structure – reducing the cost of material and labor. It also improves the aesthetic quality of the system.

Nano-Cell® Glazing



Our patented Pentaglas® translucent glazing is precision engineered with Nano-Cell® technology. This specialized panel extrusion results in the cells measuring smaller than 0.18 inches, and provides the panel with increased durability and prolonged resistance to impact. The unique cell structure also significantly improves the quality and even distribution of glare-free natural light.



One trusted system
Infinite possibilities

What's your next bright idea?



▲ **Project:** Akron Children's Hospital Parking Garage id 35531
Location: Akron, OH
Architect: GPD Group



Dynamic Shading System



Military Facility per DoD Standards

Specialized Performance Options

We understand that due to budget, occupancy and building type, not all building envelopes are made equal. That is why CPI Daylighting designed a system with an internal cavity that can be modified with additional inserts to meet the performance requirements of any building. Whether you need a system that can dynamically manage light levels in a classroom, meet forced entry standards for a military facility, or anything in between, we can help you achieve your performance goals.

- Dynamic Shading System
- Additional Insulation
- LED Lighting
- Sound Reduction (STC)
- Forced Entry Resistance
- Perforated Metal Insert





▲ **Project:** Coquille Community Center id 31260
Location: Covington, LA
Architect: Holly & Smith Architects

LED Lighting

With the integration of LED lighting, the daylighting system is transformed into an elegant night-lighting feature. With the flip of a switch, your building becomes a beacon of creativity.



Graphics

Graphics can be used to create an iconic look or to reinforce a building owner's brand through signage, logos, etc. Add textures, geometric patterns, or other unique visual elements to either the system's interior or exterior, and produce different effects that are sure to make your building stand out.



UniQuad® | Translucent Walls

Design + Engineer + Manufacture

The hallmark of the UniQuad® system is the innovative two piece panel connection, which enables the system to be unitized. The panels themselves are factory glazed and assembled for superior quality control. The unitized construction of the system results in quick, cost-effective installation.

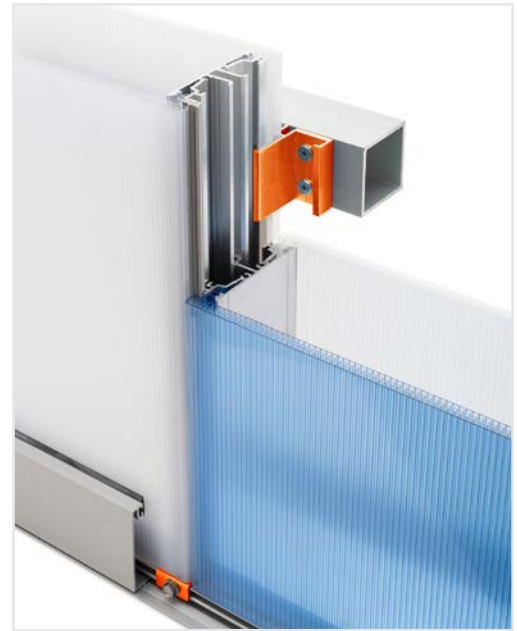
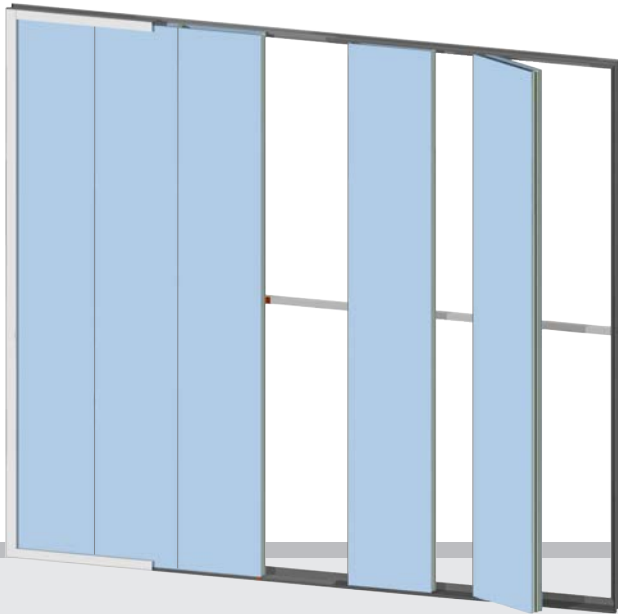

Our Innovative Technology



Frame System

The two piece frame system consists of a sill and sub-sill. It is designed so that the necessary fasteners don't penetrate the sill frame. A thermally broken frame is also available.



UniClip™

The concealed UniClip™ is designed as a structural clip, capable of withstanding heavy loads. The specialized design enables the panels to be installed quickly and remain in place without needing frame caps.



Panel Clip

The panel clip fastens directly to the internal UniQuad® structure, which prevents the glazing from breaking under extreme clip loads, as is common with other systems. The metal-to-metal connection enables the glazing to freely expand and contract. It also increases the system's ability to withstand high loads and span floor-to-slab.



1

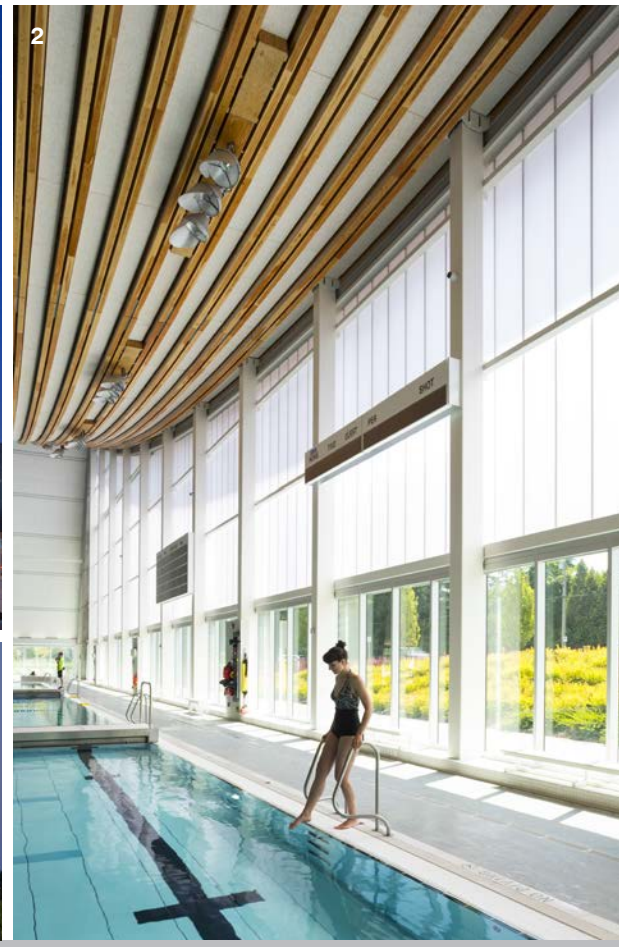

2



3

- ▲ 1 Eagle Academy id 35107
- 2 Grandview Heights Aquatic Centre id 36690
- 3 Virtua Health & Wellness Center id 23637

Product Specifications

Thickness:	4.25 in (108 mm) & 3 in (76 mm)
Width:	2 ft nominal (23.75 in) (603 mm)
Length:	Up to 44 ft long
Panel Weight:	1.5-2 lbs/ft ²
Technology:	Removable Skin Technology (RST) - Allows for the removal of the exterior panel while the interior panel remains in place
Panel Joint:	Structural member, mechanically interlocking, sealed joint
Exterior Skin:	10 mm Pentaglas® translucent panel with Nano-Cell® extrusion
Interior Skin:	10 mm Pentaglas® translucent panel with Nano-Cell® extrusion
Color Options:	Standard - Clear matte, white matte, ice white matte, blue matte, green matte Consult CPI for other available color options, including bronze matte, gray matte, white pearl low-E, and other exotic colors Note: all colors are available with a non-matte finish upon request
Bi-Color System:	Option to select one color for the exterior glazing panel, and a different color for the interior glazing panel

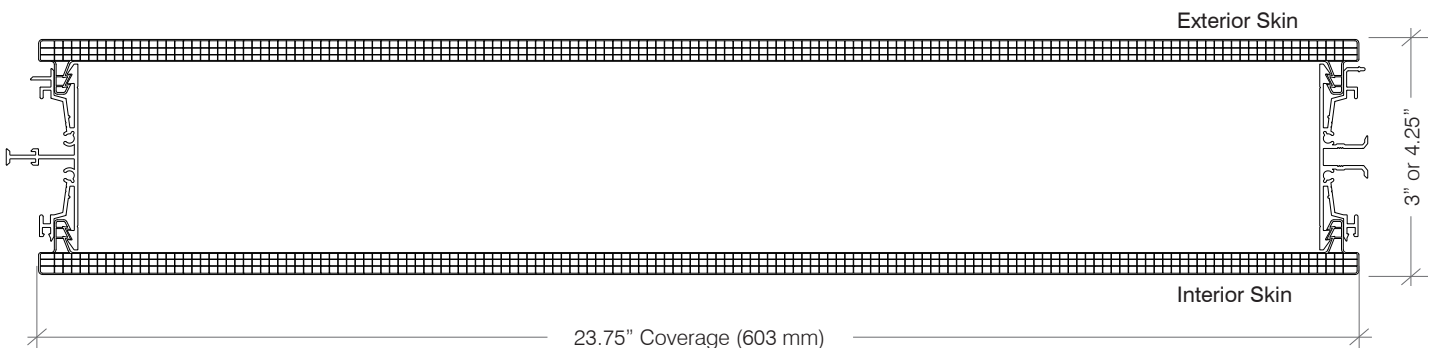

UniQuad® | Translucent Walls

Design + Engineer + Manufacture

The extreme versatility and unitized assembly of the UniQuad® system makes it the perfect system for walls and building facades. This system is also effective for clerestories and smaller scale punched openings.

UniQuad's sleek, linear aesthetic and modular construction enable the system to be easily integrated with other building envelope components.

With a wide range of colors, and the potential for incorporating graphics and lighting, UniQuad offers designers the opportunity to rethink daylighting in a creative and inspiring way.



- ▲ 1 AVCRAD Facility id 29452
- 2 Eagle Academy id 35107
- 3 Grandview Heights Aquatic Centre id 36690

Large Scale Facades

Individual panels can be manufactured up to 44 ft. tall and are able to span across floors of multi-level buildings. Panels can clear span floor-to-slab, depending on the height and loading conditions.

- ◀ **Project:** Richmond Olympic Oval id 20460
- Location:** Richmond, BC
- Architect:** Cannon Design

Daylighting Zones

Manage the level of transparency to create focal points and control views. Integrate a translucent system to maximize light while minimizing heat gain and glare.

- ◀ **Project:** Virtua Health & Wellness Center id 23637
- Location:** Washington Township, NJ
- Architect:** HGA

A Better, Brighter Building Envelope



▲ **Project:** Austin ISD Performing Arts Center id 35165
Location: Austin, TX
Architect: Pfluger Architects & Miró Rivera Architects



Pentaglas® | Cladding

Our Pentaglas® system can be used for cladding structures that enclose non-conditioned spaces.

Our cladding system can help you to achieve a variety of goals:

- Modernize the exterior of a building
- Meet hurricane standards
- Create an area for signage
- Backlighting

◀ 1 W Hotel Atlanta id 25591
2 Mission Creek Kayak Storage id 24532
3 Sarasota Police Station id 25772
4 3rd & Pine Parking Garage id 22125

Quadwall® | Skylights

Design + Engineer + Manufacture

CPI Daylighting utilizes the latest in daylighting technology to provide the market with efficient and effective solutions to meet their daylighting needs and enhance the environments where we work, learn, play and live.

We offer a wide variety of skylight options - ranging in scale from small and simple to monumental and complex. These skylights are available in a variety of standard shapes, including vaults, ridges, single slopes, pyramids, polygons, and domes. We also work with architects and designers to develop custom skylight systems.

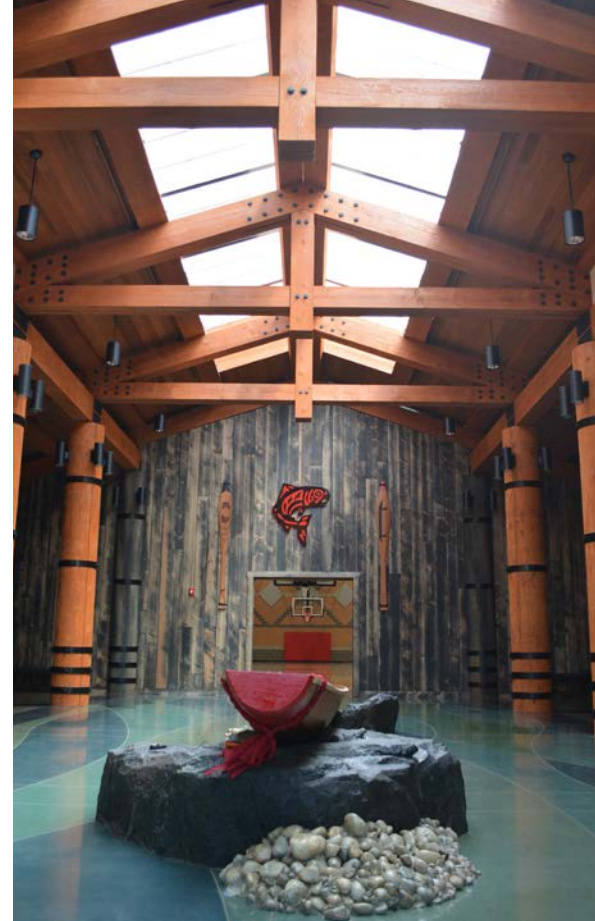

“ Not only do we now have more light in our atrium, along with watertight integrity, but we have strengthened our relationship with employees and customers by providing an environment in which they can thrive. ”

– Pete Flood | Construction project manager, SAS

▲ **Project:** Stillaguamish Community Center id 38391
Location: Arlington, WA
Architect: Womer and Associates

▶ **Project:** Bogan Park Aquatic Center id 33261
Location: Buford, GA
Architect: Wright & Mitchell Architects



Skylights over atriums and large common spaces are an impactful design feature that can make a space more inviting and create an open and comfortable environment for occupants.

◀◀ **Project:** Hologic, Inc. id 34563
Location: San Diego, CA
Architect: Smith Group Consulting

◀ **Project:** Bloomingdale's at Beverly Center id 35264
Location: Los Angeles, CA

▶ 1 Allen High School id 42976
2 University of Oregon Student Rec id 36496
3 Mall Del Norte id 23445

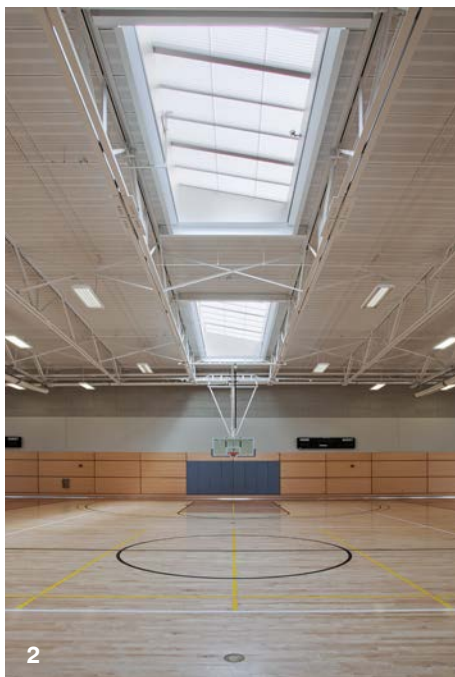

Intelasun[®] is a dynamic shading system that adjusts based on the angle of the sun and user-controlled settings. Intelasun effectively balances light-levels and eliminates solar heat gain and glare throughout the day. This dynamic system improves building efficiency by lowering peak loads and utility costs, and creates a comfortable environment for occupants. Intelasun - the perfect solution for all your high-performance daylighting needs.

SolaBlades[®]

The key to Intelasun's success is the series of rotating internal louvers, called SolaBlades[®]. The SolaBlades optimize building performance by regulating the amount of sunlight, solar heat gain and shading within a given space. With the ability to rotate a full 360 degrees, the blades gradually adjust their angle throughout the day to deliver and maintain the desired amount of light. With a system that adapts to harvest daylight when the sun is at a low angle and shade the space during peak sunlight hours, you are no longer limited to designing a system for a single daylighting scenario.



SolaBlade[®] Sun Tracking

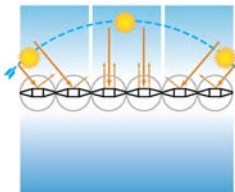
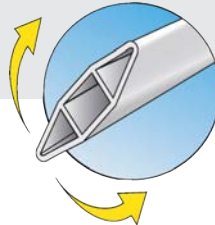

Minimum light transmission and solar heat gain

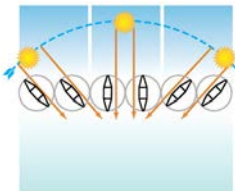

Maximum light transmission regardless of sun angle

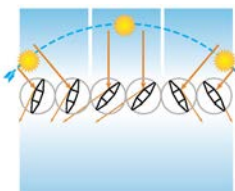

Blades are angled to diffuse light transmission to suit user preferences



▲ **Project:** San Benito High School id 40711
Location: Hollister, CA
Architect: Aedis Architects

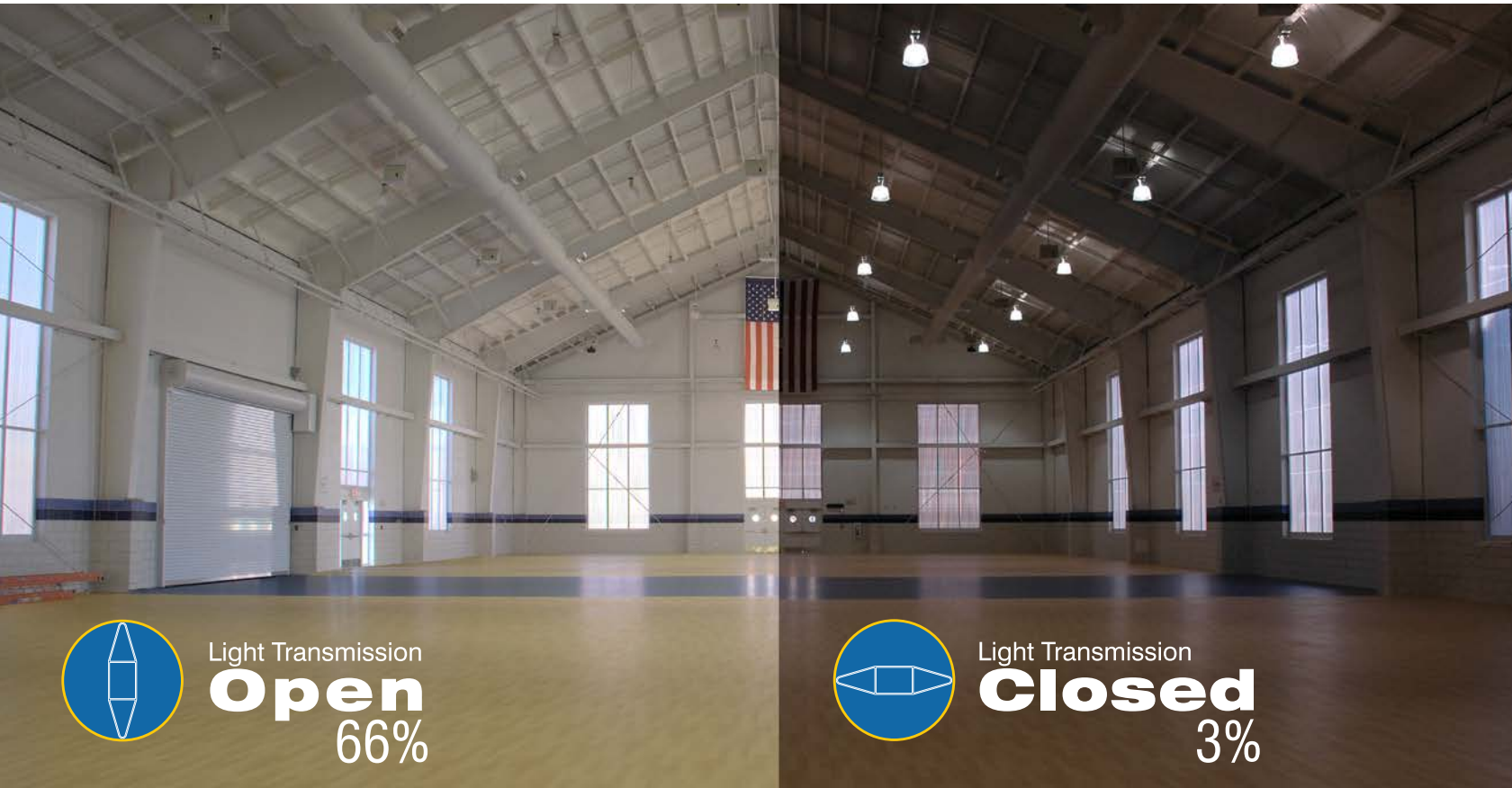

Light Transmission
Open
 66%



Light Transmission
Closed
 3%

▲ **Project:** Great Lakes Naval Training Facility id 20405
Location: Great Lakes, IL
Architect: Wight & Company

Dynamic Daylighting

Sensors on the exterior and interior of the building enable the system to track the sun and adjust to maintain optimal light levels throughout the day. The system can be programmed to be fully automated or operated manually from a wall-mounted control. When completely open, the system achieves a light transmission of sixty-six percent, while closing the blades will reduce the light transmission to a mere three percent.



▲ **Project:** University of Oregon Student Rec id 36496
Location: Eugene, OR
Architect: Robertson Sherwood Architects & RDG Planning Group



▲ **Project:** da Vinci Arts Middle School id 26248
Location: Portland, OR
Architect: SRG Partnership

BriteWay™ | Canopies

Design + Engineer + Manufacture

CPI Daylighting is a single source provider of BriteWay™ translucent canopies, offering flexible design options that include both pre-engineered and customized systems from the ground up.

Our canopies utilize patented Pentaglas® translucent glazing, which is precision engineered and extruded to have a Nano-Cell® configuration. This unique glazing extrusion results in superior durability and produces a more even distribution of glare-free natural light into adjacent spaces that would otherwise be cast in shadow.

Pentaglas is designed as a standing seam system that utilizes an interlocking mechanical connection. The innovative double-toothed edge on the up-stands of the panels enables this system to withstand extremely high loads. Systems designed and certified for hurricane resistance are also available.

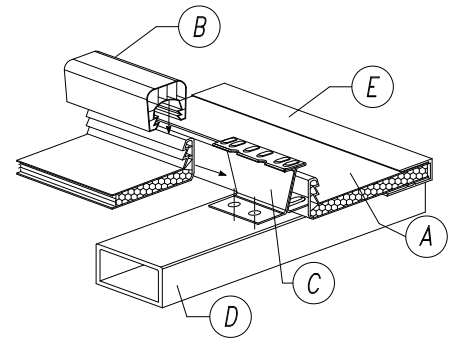

- A** Pentaglas® glazing panel
- B** Double-toothed panel connector
- C** Stainless steel panel clip
- D** Aluminum purlin substructure
- E** Aluminum framing system



- ◀ **Project** Tanger Outlet Mall id 36369
- Location** Oxon Hill, MD
- Architect** Adams + Associates Architecture

- ◀ **Project** Monrovia Station Square id 40160
- Location** Monrovia, CA
- Architect** IBI Group

Clearspan Canopies ▶

The innovative clearspan design eliminates the need for cross-bracing, which opens up the space below the canopy structure. Our clearspan canopies are pre-engineered based on specific design criteria, and are an economical solution that provides shelter while also allowing natural light into adjacent spaces. The rust-free aluminum structure offers excellent durability and system longevity.



▲ **Project** Norwalk Hospital id 32016
Location Norwalk, CT
Architect Freeman White

▲ **Project** CTA - Cermak Green Line Station id 37707
Location Chicago, IL
Architect Ross Barney Architects

- ▼ 1 Metropolitan MSC id 40892
- 2 Kaiser Town Park Community Medical Center id 3356
- 3 USCB Recreation Center id 38857
- 4 Moanalua Shopping Center id 20809

“The versatility of the Pentaglas® canopy and framing system allowed us to get creative with the concept.”

– Christopher Souza | Architect, AECOM



◀ **U-Lite®**

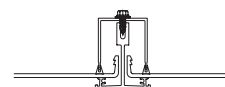

Monolithic standing seam panel system for low slope canopy applications

- High-impact resistant
- Long span capabilities
- Exposed edge design



◀ **LiteBrow®**

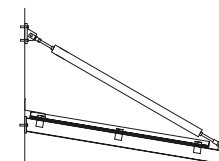

Suspended translucent canopy system

- Highly durable (designed for +/- 120 psf combined loads)
- Economical modular system (Standard sizes: 4 ft, 8 ft & 12 ft)
- Custom design options available

Retrofits & Renovations

Design + Engineer + Manufacture

Why Renovate?

- Outdated or degenerating systems are underperforming
- Discoloration has resulted in a significant decrease in light levels
- Deterioration is causing leaks and potential structural failures

We offer a variety of simple and effective turn-key retrofit and renovation solutions designed to reglaze, over-glaze or replace existing systems that are underperforming or are in desperate need of repair due to damage or deterioration.

Our two panel system ensures that your building envelope is not compromised in the future, as the interior panels will be able to remain intact indefinitely.

Skylight retrofits and renovations can play a key role in revitalizing environments that are suffering from lack of adequate natural lighting.

Deteriorating skylights often block out blue spectrum light, which accounts for the majority of health benefits associated with natural light.

We Renovate...

- Glass
- Acrylic
- Fiberglass
- Polycarbonate



Reglaze

The glazing system will be replaced and the existing structure will be evaluated and reused when possible.

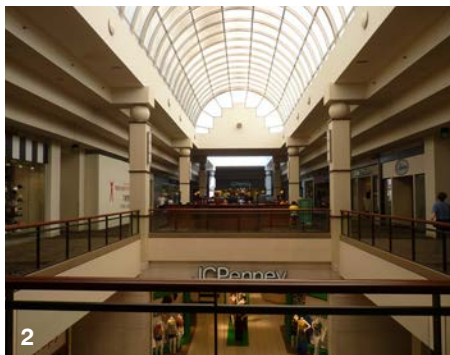

Overglaze

Pentaglas® systems can be designed to envelop leaking systems if their performance is otherwise uncompromised. This option is typical for systems that provide enough light, but may be deteriorating, leaking or need additional insulation performance.

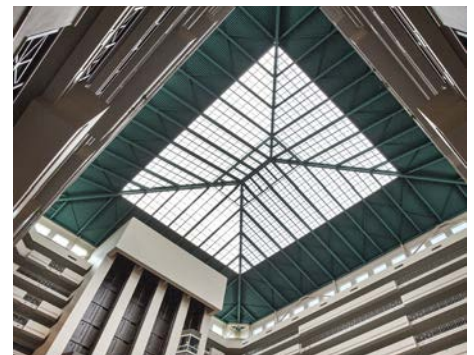
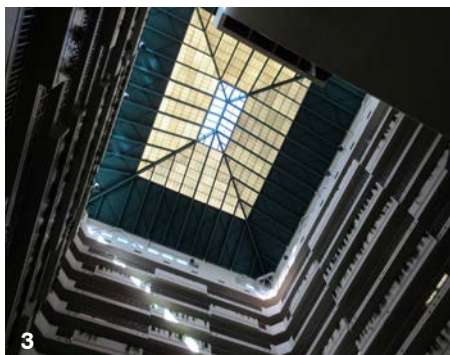

Replace

The entire existing system is disassembled and removed and a new system will be installed in its place.

Before

After



Before



After

▲ **Project:** Pembroke Lakes Mall id 39972
Location: Pembroke Pines, FL

- ◀ 1 Lakewood Mall id 39224
- 2 Town Center at Cobb id 27224
- 3 Embassy Suites id 34534

“ The difference in the lighting in the hallway and the gym is dramatic. We rarely need to use the lights in the hall because there is so much natural light. ”

– John Grote | Executive Director, Northside Community School

▼ **Project:** Raleigh Memorial Auditorium id 36730
Location: Raleigh, NC
Architect: REI Engineers

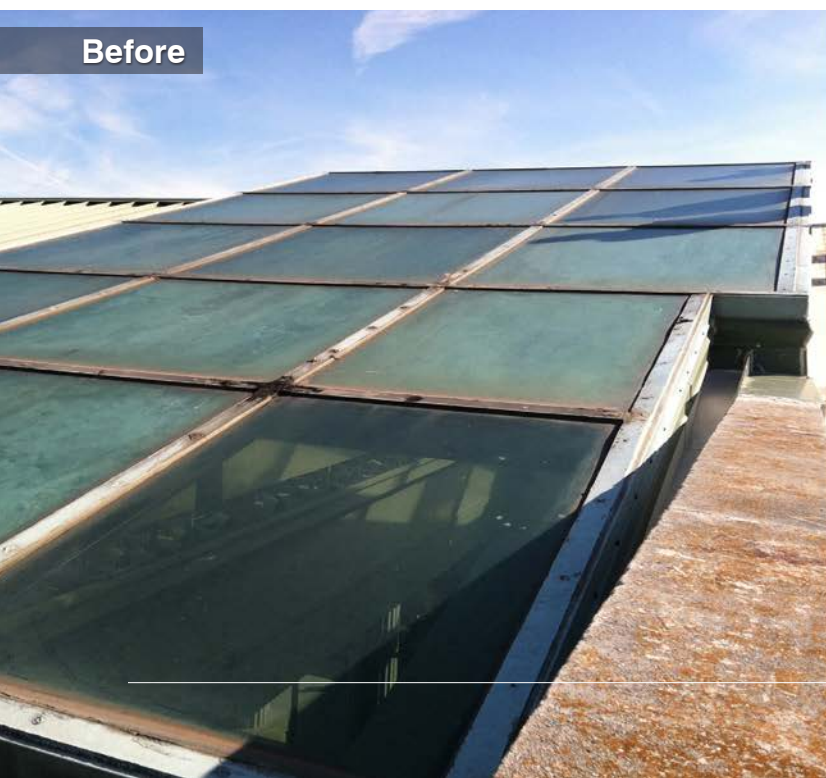

Before

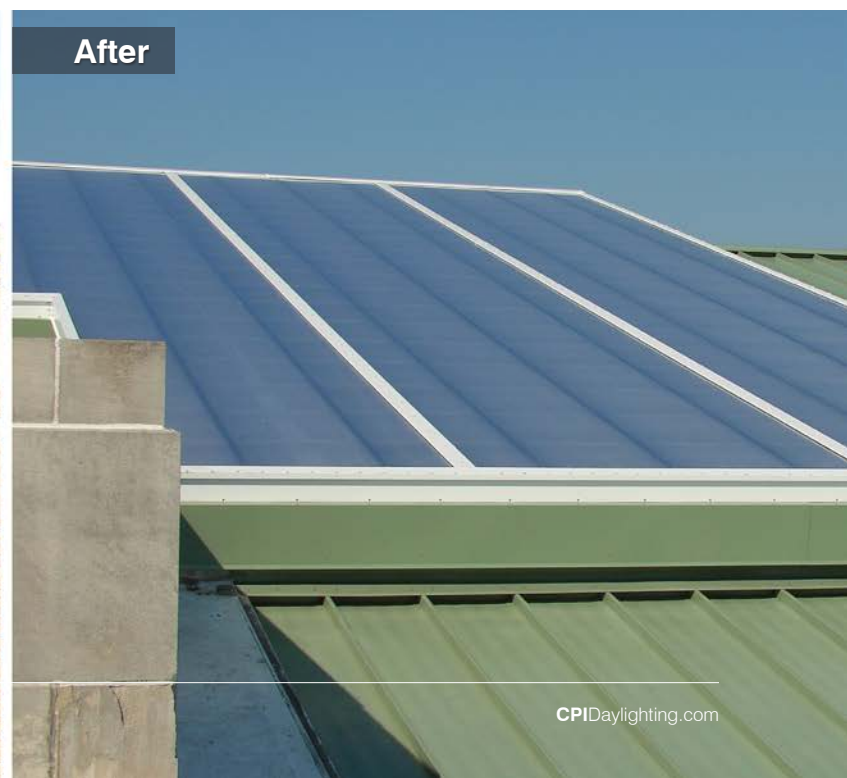

After



To learn more, visit:

www.cpidaylighting.com
www.intelasun.com

© 2017 CPI Daylighting, Inc. All rights reserved.

CPI Daylighting, Inc. reserves the right to change, discontinue or modify our products, specifications and designs at any time without notice and without incurring obligations. - Printed in the U.S.A.



CPI Daylighting, Inc.

28662 N. Ballard Dr.
Lake Forest, IL 60045 U.S.A

800.759.6985 847.816.1060
Fax 847.816.0425

